



VIJUK **GLUED-MINIATURE-BOOKLET SYSTEM**

Innovative high-speed production of booklets and more!



- A** Initial folding and spine glue application is done at Station I of the VIJUK-H+H KL 112 FOLDER with flat-pile feeder.
- The number of folding plates and the many options available for this folder make it the most flexible and versatile in small-size folding. (Brochure available.)

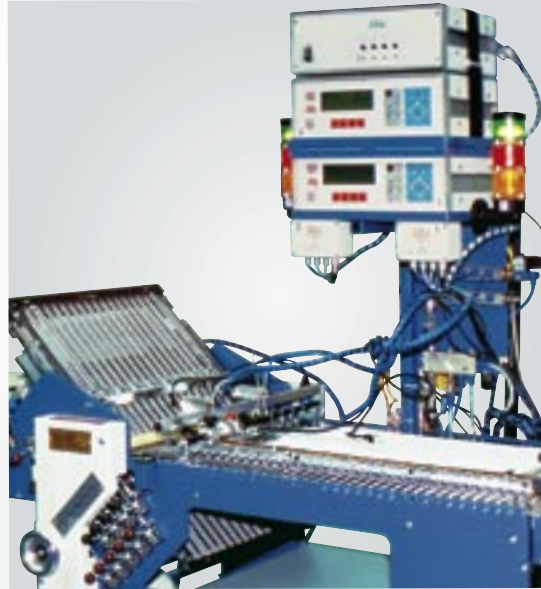

- B** The GLUE VERIFICATION SYSTEM with ON-THE-FLY GLUING gives you cost savings and ensures that the booklets will be complete and intact.
- Glue is applied consistently without pausing the machine, giving you time-efficiency as well as quality control.
 - Detection is carried out by laser-monitored measuring of the profile height of glue lines or dots. Any kind of glue can be used, without any additives.
 - It verifies glue dots and lines with diameters or widths from 1 mm.
 - Glue consumption is lower because you can use a smaller amount of glue.
 - A two-stage warning system sounds and stops the process.

VIJUK

GLUED-MINIATURE-BOOKLET SYSTEM



VIJUK GLUED-MINIATURE-BOOKLET SYSTEM

Each bookletmaking system is custom designed to solve individual company needs.

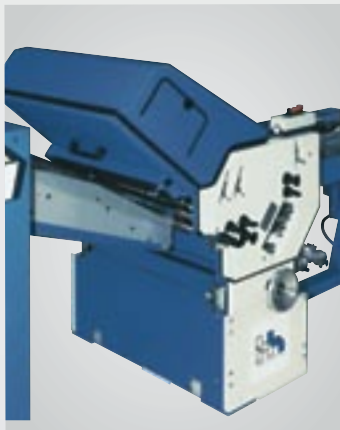

- D** At the H+H M-7 BUCKLE FOLDER, Station II, the pre-slit shafts perforate the glued sheets to allow air release to eliminate wrinkling while they are folded into booklet form.
- The sheets are folded at the spine glue line and sent to the trimming unit.
 - The folder's large diameter rollers easily handle coated stock and thick booklets.
 - It is pictured with the optional noise reduction hood. (Brochure available.)



- E** As the booklets go through the EMC 300 TRIMMER UNIT, they are face trimmed.
- Then they are head & foot trimmed along with gutter trimming if the production format is two- or three-up (1).

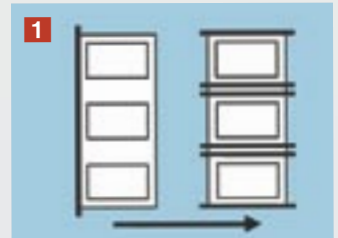

Face trimming; then head, gutter, and foot trimming in three-up production.

- It makes booklets from 1 $\frac{3}{16}$ " x 1 $\frac{5}{8}$ " to 11 $\frac{7}{8}$ " x 4 $\frac{1}{4}$ " (depending on the number of booklets in the format).

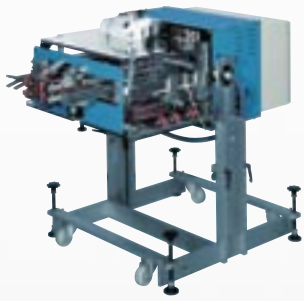

C The VIJUK-G&K ZK 500 KNIFE FOLDING UNIT (right-turn-angle) makes the first cross-fold in systems that make booklets with up to 40 pages.

- If the number of pages required is up to 20 pages, the ZK 500 Knife Folder is not necessary.
- The knife folder can also be used off-line for folding signatures and booklets (to up to 144-pages, depending on material, format, size, etc.), or for special commercial folding applications. (*Specification sheet available*)

SMALL SPINE-GLUED INFORMATION BOOKLETS ARE...

More convenient

- Information can be indexed on pages for quick, easy reference.
- A booklet attached to a container is handy for repeated reference.

More attractive

- Stitchless, glued-spine booklets give you a neat, esthetic package presentation.
- Shaped booklets add interest as well as attractiveness.



F The finished booklets leave the trimming unit onto the SHINGLE DELIVERY UNIT.

BOGRAMA punching/cutting machine option...



Head & foot trimming

Face trimming



- Add hole punching, die-cutouts or shaped booklets for your customers by installing the **BOGRAMA** automatic, multi-purpose guillotine cutting, die-cutting, hole-punching, and perforating machine in place of the EMC 300 Trimmer.
- In addition to booklet trimming, it will perform perimeter or interior die cutting, hole punching, and perforating on sheets

or booklets—1-up to 3-up.

- It operates independently or in line with folders, stitchers and collators.
- Format sizes: max 8 5/8" x 17 5/8" or 8 5/8" x 26 3/4" ; min 1 1/2" x 1 7/8". Cutting, punching and die cutting thickness: up to 3/16". Perforating thickness: up to 1/16". Production speed is up to 10,000 c/hr. depending on format, product and stock.

CUSTOMIZE with optional attachments...



The VIJUK-H+H MULTI-TASK FOLDING SYSTEM offers timed gluing, timed perforating, timed scoring, and timed cutting in a single folding cycle.

- Installed on the Vijuk Glued-Miniature-Booklet System, it will allow you to make booklets with graduated pages, calendars or coupon books with tear-out pages, self-contained booklet-mailers with a drop-out or perforated pull-out reply card, and more.

Timed perforating

- ◀ A continuous-load **ROUND-PILE FEEDER** can be specified for the production of larger booklets.

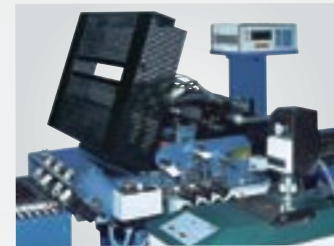

- ◀ **DESTA PRESSING UNIT** with high pressure rollers make leaflets and booklets more compact—for easier package insertion and storage space reduction.
- Setup is quick and easy. The roller caliper can be set without tools.
- Variable input height allows the pressing units to be used in line with other folders or stitchers.



Other optional equipment for efficiency...

- Bar code scanner
- Predetermined counter
- Precutter shafts
- Pressing/stacking units
- Gluing devices
- Crimping device
- Cutting unit
- Tipping unit
- Pick and place device
- Double-stream unit for second station
- Double-sheet detector (programmable to allow time for product to clear rollers)
- Batch-counting photocell and kicker system
- Vertical-stack delivery unit for miniature booklets
- Mobile shingle delivery unit
- Transfer unit
- Transfer unit with spreading device
- Noise reduction hoods (top section only)

*W*e appreciate your interest in Vijuk Equipment, Inc.

For all your finishing needs, Vijuk proudly offers high-quality equipment and excellent support and service. Please contact us for:

- *G&K Folders and auxiliary equipment*
- *H+H Folders and auxiliary equipment*
- *Vijuk MV Outsert Systems*
- *VIJUK 321-T Saddle Stitching Systems*
- *Setmaster Collators*
- *Victory® Die Cutters*
- *Multi-BookPad Systems (side-stitch/tape/trim systems)*
- *Hydromat 3-Knife Trimmers*
- *Material Handling Equipment*
- *Other specialty or customized equipment*
- *Spare parts for all Vijuk equipment*

715 Church Road, Elmhurst, Illinois 60126 • (630) 530-2203 FAX (630) 530-2245
info@vijukeyquip.com • **www.vijukeyquip.com**

